

Manufacturer's Declaration as per EU-Directives

Page 1 of 2

The manufacturer	BRAY Armaturen & Antriebe Europa, D47807 Krefeld
declares for the product:	for double excentric Butterfly valves Series: Series TRI-LOK Series <40/45> Series <S04> <ul style="list-style-type: none"> • manually operated valves • with electric, pneumatic, hydraulic actuator with bare shaft for
These products meet requirements of the following European Directives as follows: Pressure Directive 97/23 EG (PED): When Art 3 Clause 1.3 or Art. 3 Absatz 3 of the Directive apply: A conformity with this clause of PED is declared. The instructions no. OM0001E for the actuator and the relevant instruction for the valve shall be observed. Machinery Directive 2006/42 EG (MD) An butterfly valve is a not complete machine only within the meaning of the European Machinery Directive 2006/42 EC and is destined to be installed at a pipe system – both together then are a complete machine within the meaning of this European Directive. For the customer's risk analysis the Table at page 2 of this Declaration lists up some requirements of the MD in relation to the valve-actuator unit. The operation instructions no. OM0001E for the valve and the relevant instruction for the actuator shall be observed. In relation to the Directives above shall be observed by the user: <ol style="list-style-type: none"> 1. The user shall observe the „Valve destination“ as defined in the <Instruction ButterflyValve TRI-LOK & SERIES 40/41/42/43/44/45 AND S4 - OM0001E > and shall observe all safety advices that may be relevant at use. Disregard of this advice can invalidate this declaration. 2. The commissioning of a valve-actuator unit is not permitted as long as the conformity of the pipe system into which this unit is installed with all relevant European Directives is not yet declared by the person or institution responsible. The manufacturer BRAY has made and documented all necessary risk analysis – the responsible person is Mr. Franz Ritzberger at BRAY Armaturen & Antriebe in Krefeld, Germany. 	
Krefeld, den 02.03.2011 <div style="text-align: center;">  _____ KURT BAIER, General Manager </div>	
The start-up of an actuator/valve unit is only permitted after the valve has been properly assembled with the pipe section – this only prevents the danger of physical injury of the personnel.	

Standards applied:

EN 593 EN 12100	Metallic Butterfly Valves Safety of machinery – General
----------------------------------	--------------------------------------------------------------------------

Type description & technical data:

BRAY-catalogue <Series TRI-LOK & Series 4[.]>

Manufacturer's Quality Management System

ISO 9001:2008	<i>Register-N° and Name of the notified body</i> Bureau Veritas, Id. number 0062
----------------------	--------------------------------------------------------------------------------------------

Manufacturer's Declaration as per EC-Directives Page 2 of 2	
Requirement EC 2006/42/Annex I	<p>for double excentric Butterfly valves Series:</p> <p>Series TRI-LOK Series <40/45> Series <S04></p> <ul style="list-style-type: none"> • manually operated valves • with electric, pneumatic, hydraulic actuator with bare shaft for
1.1.1, g) Valve destination	See original installation and service instruction " OM0001E "
1.1.2.,c) foreseeable misuse	See original installation and service instruction " OM0001E "
1.1.2.,d) protecting measures for personnel	Same as the pipe section into which the valve is installed.
1.1.2.,e) accessories for maintenance	No special tools are necessary.
1.1.3 material in contact with the fluid	The materal of wetted parts (valve body or body liner and disc) in contact with the fluid is specified in the order acknowledgement and/or on the valve's marking. The relevant risk analysis is the responsibility of the user.
1.1.5 handling	See installation and service instruction " OM0001E "
1.2 and 6.2.11 control system	Is the responsibility of the user in combination with the instruction of the actuator.
1.3.2 withstand to stresses	For parts under pressure: See declaration of conformity to the PED 97/23/EC For functional parts: Ensured at contractual use of the valve.
1.3.4 sharp edges or angles	Requirements fulfilled.
1.3.7/8 risks related to moving parts	Requirements are fulfilled at contractual use of the valve. No maintenance or service is allowed when the valve is pressurized and/or it is connected to the control system.
1.5.1 – 1.5.3 energy supply	In the responsibility of the user in combination with the instruction of the valve.
1.5.7 -explosion	☉-protection may be necessary. This shall be confirmed by BRAY in the order acknowledgement.
1.5.13 emission of dangerous substances	Not applicable at not dangerous compressed fluids.
1.6.1 maintenance	See installation and service instruction no. " OM0001E "
1.7.3 marking	Valve: see original installation and service instruction no " OM0001E " Actuator: see actuator instruction
1.7.4 service instruction	See original installation and service instruction no. " OM0001E " and actuator instruction at standard actuator destination. At any special application additional notes and warnings may be necessary but are in the responsibility of the user.
Requirements from Annex III	The valve is not a complete machine but a not complete machine only. No CE marking for conformity with the directive 2006/42/EG.
Requirements from Annexes IV, VIII & XI	Not applicable.

Requirements as per EN 12100	
1. Scope	Basis for the analysis is the Product Standard EN 593: <Metallic butterfly valves>. <i>Note:</i> <i>For the requirements as per clauses 4 to 6 of EN 12100 it is assumed that the user has made a risk analysis for the valve/actuator unit installed into the pipe section under the service conditions– such analysis is not possible for BRAY.</i>
3.20, 6.1 inherent design	The valve has been designed at the principles of <inherent safe design>.
Analyse as per clause 4, 5 and 6	The knowledge of documented malfunctions and misuse at the manufacturer BRAY as per ISO 9001 are the basis of this instruction.
5.3 Limits of the machine	The limits of the valve are defined as per clause A2 <Valve destination> - and the limits of the valve/actuator interface as well.
5.4 Decommissioning, waste management	Not in the responsibility of the manufacturer BRAY
6.2.2 Geometric factors	The valve shell (body, covers) enclose all moving parts of the valve: no risk at use as defined in clause A2 of this instruction OM0001E.
6.3 Technical protective devices	not applicable.
6.4.5 Instruction	Valves with actuator operate automatically after connection to the plant control system. Necessary information for service and maintenance are included in section C of this instruction OM0001E.

**Original-installation instruction for double excentric butterfly valves
Series <Tri-Lok>, <Series 40/45> and Series <S4A>
with service / maintenance instruction and technical Annex**

for a valve as <not complete machine> as per European Machinery Directive 2006/42/EG
and as per European Pressure Directive 97/23/EG

INDEX	Page
Manufacturer's Declaration as per EC-Directives	1
A) General	
A1 Pictograms	4
A2 Valve Destination	4
A3 Marking of the valve	4
B) Installation and functional check	
B1 Important safety warnings at installation	5
B2 Transport und storage	5
B3 Precondition to install a valve	5
B4 Steps at installation	6
B5 Pressure test of the pipe system	7
B6 <u>Additional information</u> Valve disassembling valve from the pipe section	7
C) Service and maintenance	
C1 Important safety warnings at service and maintenance	7
C2 Commissioning	8
C3 Maintenance	8
C4 Troubleshooting	8
D) Technical Annex & Valve Data	
D1 Technical specification for all Series	9
D2 p/t ratings	9
D3 Drawings / material for triple excentric Butterfly valves TriLok	11
D3 Drawings / material for double excentric Butterfly valves Series 40	12

More information

This manual, BRAY-catalogue-pages and other information – even in other language – may be asked from sales@bray.de or from

<p>BRAY Armaturen & Antriebe Europa Europark – Fichtenhain A , 13b · D-47807 Krefeld <i>Email: sales@bray.de</i> <i>Tel: +49 2151 5336 0</i> <i>Fax: +49 2151 5336 242</i></p>



A General

This instruction may support the user to store, install, start-up, use and maintain BRAY-butterfly double excentric valves of Series TRI-LOK, Series <40/45> and Series <S04> with a manual, electric or pneumatic/hydraulic actuator.

The manufacturer's instruction of the actuator and the instructions of the plant control system shall be observed accordingly by the user.

A1 Pictograms

Warnings and notes of this manual are marked with pictograms:

 xxxxx	Danger / Warning Points out a dangerous situation which may cause personal injuries or death.
	Advice Has to be respected
	Information Information useful to follow

If these notes and warnings are not respected by the user, dangerous situations may occur and may invalidate the warranty of the manufacturer.

A2 Valve destination

A double excentric BRAY-butterfly valve (i.e. **TRI-LOK, Series <40/45> and Series <S04>**) complies with the requirements of EN 593 <Metal Butterfly valves> and ANSI B16.34 <Valves with Armaturen with flanged / welded / screwed ends> and is exclusively destined to let pass or shut off media in the allowable pressure and temperature range.

This pressure and temperature range is explained in Annex D2 – in relation to the body material.

All requirements of clauses B1 and C1 <Important information for the user> shall be observed

Note

Valves of these Series may be used in OPEN- or CLOSED-position. If a butterfly valve shall be used for control service the flow conditions shall be agreed between BRAY and the customer/user.

A3 Marking of the valve

Each valve supplied is marked as follows:





Valve marking (example)

The marking shall not be damaged or covered (do not paint over!) to permit the valve identification if necessary.

B Installation and functional check

	<p><i>This instruction includes safety recommendations for foreseeable risks at installation into a pipe (and control) system.</i></p> <p>The user is responsible to complete this instruction with warning notes for system-specific aspects. All requirements of the system shall be observed.</p>
-----------------------------------------------------------------------------------	------------------------------------------------------------------------------------------------------------------------------------------------------------------------------------------------------------------------------------------------------------------------------------------------------



B1 Important safety warnings at installation

	<ul style="list-style-type: none"> Installation shall be performed by qualified personal. Qualified are those persons who, due to experience, can judge the risks and execute the work correctly and who are able to detect and eliminate possible risks. A valve shall be assembled into the pipe system as supplied by BRAY – any modification without approval of BRAY is forbidden and determines the manufacturer's liability. The valve (<i>and the actuator – if any</i>) marking shall fit to the plant system characteristics - see clause A3 <valve marking>.
 Danger	<ul style="list-style-type: none"> A butterfly valve installed as an end closing-off of a pipe section under pressure shall be equipped with a blind flange or cover to prevent hazardous leakage to outside. <i>A valve with actuator not properly installed in a pipe section: :</i> Danger of jamming one's hand or fingers between valve body and disc: Do not operate a valve not capped by the pipe system! Any actuating of a valve not installed is the full responsibility of the user.

B2 Transport and storage

The valve – and valve/actuator units as well – shall be shipped and stored with care.

- Valve/actuator units shall be in its protective packing. Store units >25kg on a pallet for easy handling.
- Protect the valve from harsh environmental conditions, such as dirt, debris and humidity.

	<p>Protect specifically the high performance machined surfaces of the body seat and the seat ring in the disc from any damage at transport and installation: Even small scratches may cause leakage and high costs for repair.</p>
	<p>If a hoist shall be used to handle a valve or a valve/actuator unit, fix the the lifting devices at the valve body, not at the handwheel. <i>But a lifting device may be fixed at an actuator which is much heavier than the valve.</i></p>

- A butterfly valve is supplied in slightly open position and shall be stored accordingly. Do not operate the valve.
- Unpack a valve or valve/actuator unit not earlier than just before installation.

B3 Precondition to install the valve

- Ensure to observe the <Valve destination> specified in clause A2 and the valve body and disc materials to be suitable for the fluids in the plant – see the relevant valve markings in clause A3 and the pressure/temperature limits specified in Annex D2.
- As a rule the valve is supplied with an actuating device ready for use.
 When a valve is supplied without actuating device take care to install it in closed position and do not operate a bare shaft.



	<p><i>A gear or actuator supplied is adjusted for the service condition:</i> Do not disadjust the OPEN and CLOSED end positions of the valve supplied as long as the valve is tight.</p>
-------------------------------------------------------------------------------------	---------------------------------------------------------------------------------------------------------------------------------------------------------------------------------------------------------------

- The flanges of the connecting pipe shall fit to the valve dimensions and shall have parallel connecting surfaces. The <mating surfaces> of the pipe flanges shall be smooth and free of grooves.



- The valve is supplied in almost closed position and shall be installed accordingly to protect the disc border from damage at installation: Maintain this supply position and
- Ensure the connecting pipe having sufficient clearance for the disc pivoting 90°.

B4 Steps at installation

- Take of protecting caps or packaging from the valve – if any.
Unpack a valve or valve/actuator unit not earlier than just before installation.

	<p><i>Valves Series TRI-LOK and Series 4[.] are suitable for both flow directions. But the optimal installation position is marked by an arrow at the valve body:</i></p> <p>The valve should be installed with this “arrow”-direction same as the direction of the pressure against the closed disc. This direction may be different from the flow direction of the opened valve.</p>
	<p><i>The pipe section shall be free of foreign particles at installation, before the valve is closed for the 1st time::</i></p> <p>To prevent leakage at the disc seal, inspect and be sure, that the valve inside, the pipe waterway at both adjacent pipe insides are free from dirt, rust, pipe scale, welding slag and any other foreign material – for flushing see text below.</p>
 Danger jamming o- ne’s hand	<p><i>Take special care at a pneumatic valve actuator <fail safe with spring to open>:</i></p> <p>This <fail safe>-actuator shall be closed temporarily during installation: Take care to keep the valve 100% closed at set-in and centering at the connecting pipe flanges. Do not disconnect the temporary pressure supply until the flange bolting is correctly fastened as described above.</p>

- Preferably install the valve shaft in horizontal position. An actuator shall never be installed downwards.
- At installation into an existing pipe system be sure, that the gap between the 2 pipe flanges has sufficient clearance to protect especially the valve body sealing surfaces from damage. Then centre the valve exactly and fasten the flange bolting crosswise in little steps.
- When an actuator bigger than the valve shall be installed in horizontal position of the valve, the plant supervisor shall check and decide if this actuator shall be supported in site.
- To connect an actuator the relevant manufacturer’s instruction applies.

	<p><i>Valve with electric actuator only:</i></p> <p>Check and be sure that the signal of the limit switch stops the valve in the CLOSED and OPEN end-positions. A signal of the torque switch may be used as a failure-message. More instruction is given in the actuator manual.</p>
 Gefahr	<p>Defaults of signals and signalisation could mean danger for the health of the user and/or cause damage in the piping system</p>

- Last step of the installation (preferably after the pipe section flushing):
A manually operated valve must be operated with normal handforce for the full 90°-stroke.
Valve with actuator: Make a functional test with the signals of the plant control system: Open and close the valve to the tight position and check the correct function and signalisation of the limit switches (if any).
- Then open the valve to allow the filling of the pipe system. At any filling and flushing limit the flow velocity to 1-2 m/s.
- At any trouble see clause C4 <Trouble shooting guide>.

B5 Pressure test of the pipe system

The valve has been pressure tested by the manufacturer as per EN12266-1 or ISO 5208. Observe at the pipe system pressure test to prevent functional overload of the disc:

- **valve in OPEN position:** The test pressure shall be limited to **1,5 x (PN or PS)** – see valve marking. (*PS = maximal admissible pressure at 20°C*).
- **valve in CLOSED position:** The test pressure shall be limited to **1,1 x (PN or PS)**.
- In case of leakage, observe clause 7 <Troubleshooting>.

B6 Additional info: Valve disassembling from the pipe section

Observe the same safety measures as for the pipe section and for the electric/pneumatic plant control system:

- (*if any*) Interrupt the pressure and control supply permanently.
- Open the valve and drain and discharge the pipe section.
- Loosen the flange connection and disassemble the valve – take care not to damage the valve lining.
- At (temporary) storage observe clause B2 <Transport and storage>.

C) Normal service and inspection

As per European Directives 97/23/EC (PED) and 2006/42/EC (MD) the layout engineer shall make a risk analysis for the pipe system. The manufacturer BRAY supplies the following documents for this task:

- This installation and service instruction,
- the initial <Manufacturer's Declaration to EC-Directives>.



This instruction includes safety notes for industrial application for any foreseeable risk at use of the valve.

It is the responsibility of the user/layout engineer to complete this instruction with warning notes for plant-specific risks.

C1 Important safety warnings at service and maintenance

	<ul style="list-style-type: none"> • Installation shall be performed by qualified personal. Qualified are those persons who, due to experience, can judge the risks and execute the work correctly and who are able to detect and eliminate possible risks. • The valve function shall correspond to the <Valve destination> as specified in clause A2 and the service conditions shall be in line with the valve marking see clause A3 • The risk to touch a hot valve surface depends from the fluid temperature only – this is the user's responsibility and cannot be anticipated by BRAY. • A valve shall have been assembled into the pipe system and shall be used at service as supplied by BRAY – any modification without approval of BRAY is forbidden and determines the manufacturer's liability. • A butterfly valve installed as an end closing-off of a pipe section under pressure shall be equipped with a blind flange or cover to prevent hazardous leakage to outside.
 Attention	<ul style="list-style-type: none"> • <u><i>The valve has a stuffing box at the actuating shaft.:</i></u> Ensure at first putting under pressure to check the tightness of the stuffing box. In case of leakage: Tighten at once both nuts (or bolts) at the stuffing box alternating and in little steps until the leakage disappears – do not draw the bolting more than necessary!
 Danger	<ul style="list-style-type: none"> • <i>When the pipe section is pressurized:</i> Do not unscrew a cover from the valve body or the pipe flange bolting in a pressurized pipe section. At disassembling of the stuffing box the pipe section shall be completely depressurized. • <i>A valve not properly installed in a pipe section:</i> : Danger of jamming one's hand or fingers between valve body and disc: Do not operate a valve not capped by the pipe system. Any actuating of a valve not installed is the full responsibility of the user.

C2 Commissioning

A valve closes clockwise and opens anti-clockwise.

Operating Instructions for Butterfly valves TRI-LOK & Series 40/41/42/43/44/45 and S4

To operate a lever or handwheel normal manual force is sufficient. It is not permitted to use extension levers to increase the torque.

Actuated valves shall be operated by the plant control system. The adjustment of the actuator shall not be changed as long as the valve operates correctly.



C3 Maintenance

Regular maintenance is not required for valves, but the stuffing box shall be visually inspected in appropriate sequence.

In case of stuffingbox leakage:

Tighten both nuts (or bolts) at the stuffing box alternating and in little steps until the leakage disappears – do not tighten more than necessary!

C4 Troubleshooting

 Danger	<ul style="list-style-type: none"> • Ensure at any repair to observe the warning notes at clauses B1 and C1. • Ensure at any repair the pipe section to be completely depressurized 																					
Kind of fault	all Series: Measures																					
Leakage at the pipe flange or at a cover flange connection	<p>Tighten the gasket by the flange bolting.</p> <p><i>If this is in vain:</i> Replace the flange gasket(s). Observe clause B1 and C1 <Special danger..> and order new gaskets from the pipe system responsible person.</p>																					
Leakage at the stuffing box	<p><i>Try to tighten the leakage – this can be done under pressure:</i> Tighten the stuffing box by the stuffing box bolting in little steps of ¼ turn clockwise alternating at both nuts.</p> <p><i>If the stuffing box continues to leak:</i> The shaft seal shall be replaced. Observe clause C1 <Special danger...> and order spare parts and repair instruction from BRAY.</p> <p><i>If the nuts at the stuffing box shall be loosened or disassembled (anti-clockwise):</i></p> <div style="text-align: center;">  Attention: Danger for the life or health of the user: Make sure, that the pipe at both sides of the valve is completely depressurised before the actuator is disassembled from the valve disconnect the pilot pressure supply. </div>																					
Leakage at the disc in closed position	<p>Check if the actuating device operates correctly and closes the valve 100%.</p> <p><i>If this is OK, but the valve still leaks:</i> Open and close the valve several times under pressure.</p> <p><i>If after that the valve still leaks: Repair is necessary:</i> Order spare parts and repair instruction n°. B1023-1/05 from BRAY.</p>																					
Malfuncion	<p>Follow that instruction, observe clause B1 & C1 <Special danger...>, disassemble the complete valve from the piping, open the valve.</p> <p>Then disassemble the disc and replace the seat seal following B1023-1/05. Polish the body seat (=Item 8, inside border, use emery n°.250 or 400 (not more rough!), reassemble the valve and reinstall it as per clause B4.</p>																					
Kind of fault	all Series: Measures																					
Replace of body seat item 8	<p><i>If the seating inside surface is no more to repair by polishing only:</i> Observe clauses B1 & C1 <Special danger...> and order spare parts and repair instruction from BRAY.</p> <p>Disassemble the complete valve from the piping, open the valve.</p> <p>Disassemble bolts 9, seat ring 8 and gasket 7 and replace items 7 & 8. Then fasten bolting 9 crossover in little steps as following:</p> <table border="1" style="margin-left: auto; margin-right: auto;"> <tr> <td style="text-align: center;">thread</td> <td style="text-align: center;">M8</td> <td style="text-align: center;">M10</td> <td style="text-align: center;">M12</td> <td style="text-align: center;">M16</td> <td style="text-align: center;">M20</td> <td style="text-align: center;">M24</td> </tr> <tr> <td></td> <td style="text-align: center;">5/16"</td> <td style="text-align: center;">3/8"</td> <td style="text-align: center;">1/2"</td> <td style="text-align: center;">5/8"</td> <td style="text-align: center;">7/8"</td> <td style="text-align: center;">1"</td> </tr> <tr> <td style="text-align: center;">max. torque [Nm]</td> <td style="text-align: center;">22</td> <td style="text-align: center;">42</td> <td style="text-align: center;">75</td> <td style="text-align: center;">175</td> <td style="text-align: center;">350</td> <td style="text-align: center;">600</td> </tr> </table>	thread	M8	M10	M12	M16	M20	M24		5/16"	3/8"	1/2"	5/8"	7/8"	1"	max. torque [Nm]	22	42	75	175	350	600
thread	M8	M10	M12	M16	M20	M24																
	5/16"	3/8"	1/2"	5/8"	7/8"	1"																
max. torque [Nm]	22	42	75	175	350	600																

	<p>Note: Take care to centre the ring 8 correctly at disc 15 before and during bolting fastening Reinstall the valve as per clause B4.</p>
Disassembling of a pneumatic actuator	<p>. Follow clause B6:</p> <p>Pneumatic actuator spring to close:  Attention to jam one's hand</p> <p>First decompress the actuator completely before starting any repair</p> <p><i>Pneumatic actuator spring to open:</i> At disassembling and re-assembling: Observe Warning in clause B4!</p>

Order spare parts from BRAY with all information from the valve marking – see clause A3

D) Technical Annex & Valve Data

Note:

This clause is no integral part of the „Original Installation and service instruction“ but an extract from the BRAY <Product overview: Butterfly valves & actuators>. More details may be found in this handbook.

D1 Technical Specification all Series of BRAY Butterfly valves

The valves conform to

- ▶ EN953: <Butterfly valves with body of metallic materials>
- ▶ ANSI B16.34 <Valves with flanged/, welded and screwed ends>

D2 p/t-Rating diagrams

p/t-Ratings shall be taken from the relevant diagrams in the BRAY-catalogue <Butterfly valves Tri-Lok>

D3 Drawings of typical Butterfly valve Series

More information may be found in the BRAY-catalogue <Butterfly valves TRI-LOK>

**6" (150MM) TRI LOK WAFER
ANSI 150**

- 1 STEM PLUG
- 2 PLUG GASKET
- 3 UPPER/LOWER BEARING
- 4 BEARING GASKET
- 5 SPLINED STEM
- 6 VALVE BODY
- 7 BODY SEAT GASKET
- 8 BODY SEAT
- 9 BODY SEAT RETAINING
CAP SCREWS (HEX)
- 10 DISC SEAL RING
RETAINING CAP SCREWS
(HEX)
- 11 LOCK WASHERS
- 12 DISC SEAL RING RETAINER
- 13 DISC SEAL RING
- 14 DISC SEAL RING GASKET
- 15 DISC
- 16 LOCATING DOWELS
- 17 THRUST WASHER
- 18A BRAIDED PACKING RING
- 18B SOLID GRAPHITE RINGS
- 19 GLAND RING
- 20 PACKING GLAND SCREW
- 21 ANTI-BLOWOUT RETAINING
RING/ SPLIT RING
- 22 GLAND RETAINER
- 23 LOCK WASHERS
- 24 PACKING GLAND RETAINER
NUTS
- 25 SOCKET HEAD SCREWS
W/ LOCK WASHERS
- 26 MOUNTING
BRACKET / PLATE

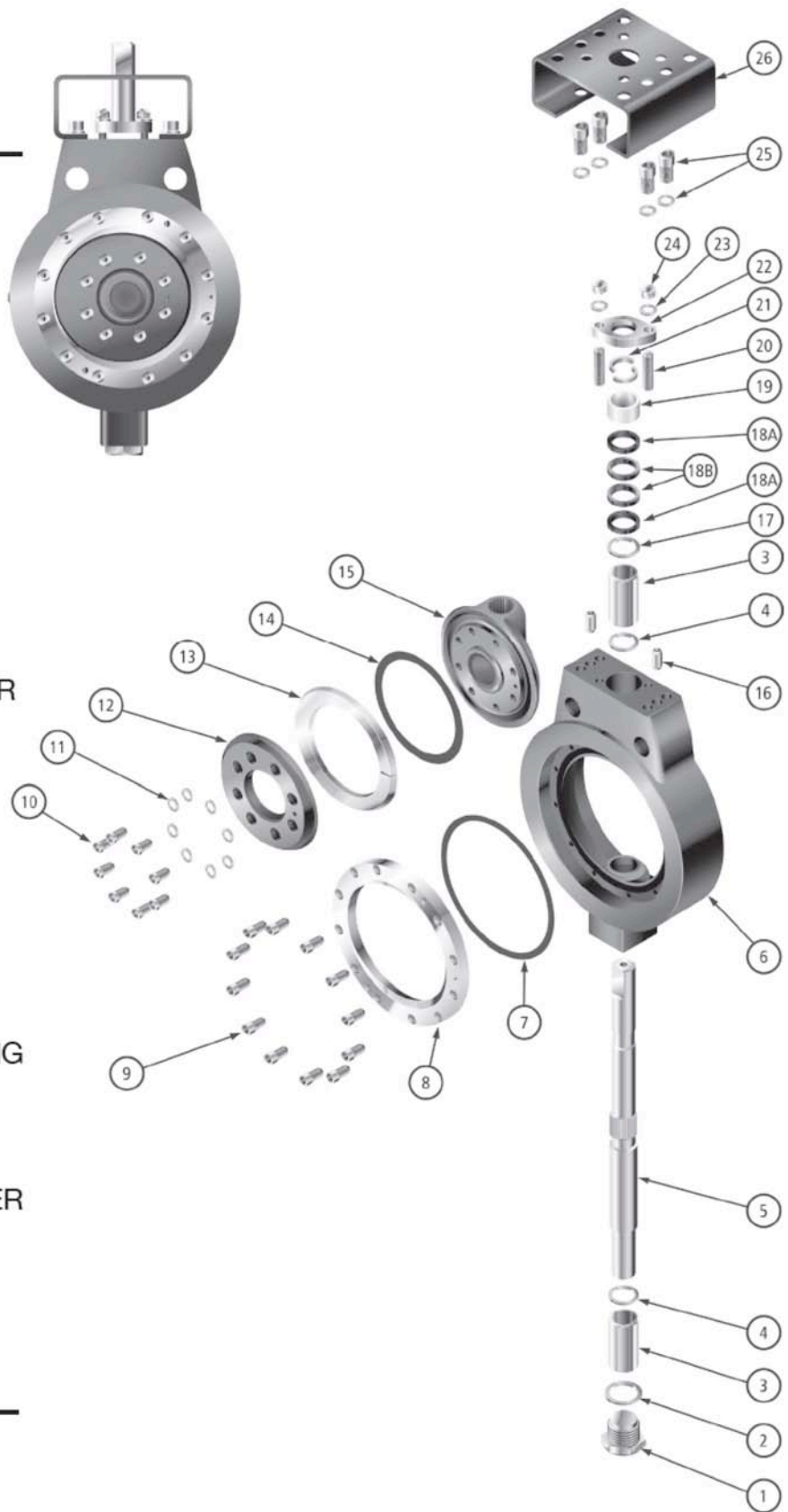

MATERIALS OF CONSTRUCTION

Item	Name
1	Body
2	Disc
3	Stem
4	Taper Pins
5	Disc Spacer
6	Bearing Assembly
7	Gland Ring
8	Stem Seal
9	Thrust Washer
10	Retaining Ring
11	Gland Retainer
12	Stud
13	Lock Washers
14	Hex Nut
15	Seat Assembly
16	Seat Retainer Plate
17	Cap Screws
18	Gasket
19	Locating Plug
20	Mounting Plate
21	Cap Screws
22	Lock Washers

