

Manufacturer's Declaration as per EU-Directives

Page 1 of 2

The manufacturer	BRAY Armaturen & Antriebe Europa, D47807 Krefeld
declares for the product:	Pneumatic part turn actuator Series 92 and 93 as per EN15714-3
<p>These products meet requirements of the following European Directives as follows:</p> <p>Pressure Directive 97/23 EG (PED): Only Art. 3, clause 3 of the Directive applies : A conformity with this clause of PED is declared. The instructions no. OM0002E for the actuator and the relevant instruction for the valve shall be observed.</p> <p>Machinery Directive 2006/42 EG (MD) An actuator is a component only within the meaning of the European Machinery Directive 2006/42 EC and is destined to be installed at a part turn valve – both together then are an incomplete machine within the meaning of this European Directive. But for the customer's risk analysis the Table at page 2 of this Declaration lists up some requirements of the MD in relation to the valve-actuator unit. The operation instructions no. OM0002E for the actuator and the relevant instruction for the valve shall be observed.</p> <p>In relation to the Directives above shall be observed by the user:</p> <ol style="list-style-type: none"> 1. The user shall observe the „Actuator destination“ as defined in the following < Operating Instructions for Pneumatic Actuator Series 92 / 93 - OM0002E > and shall observe all safety advices that may be relevant at use. Disregard of this advice can invalidate this declaration. 2. The commissioning of a valve-actuator unit is not permitted as long as the conformity of the pipe system into which this unit is installed with all relevant European Directives is not yet declared by the person or institution responsible. The manufacturer BRAY has made and documented all necessary risk analysis – the responsible person is Mr. Franz Ritzberger at BRAY Armaturen & Antriebe in Krefeld, Germany. <p>Krefeld, den 02.03.2011</p> <p style="text-align: center;">_____</p> <p style="text-align: center;">Kurt Baier, General Manager</p> <p>The start-up of an actuator/valve unit is only permitted after the valve has been properly assembled with the pipe section – this only prevents the danger of phys</p> <p><i>Standards applied:</i></p> <div style="display: flex; justify-content: space-between;"> <div style="width: 30%;"> <p>EN 15714:2009</p> <p>EN 12100</p> </div> <div style="width: 65%;"> <p>Part 3: Pneumatic part-turn actuators</p> <p>Safety of machinery – General</p> </div> </div> <p><i>Type description & technical data:</i></p> <p>Annex D and BRAY-catalogue <Series 92 & Series 93></p> <div style="display: flex; justify-content: space-between;"> <div style="width: 45%;"> <p><i>Manufacturer's Quality Management System</i></p> <p>ISO 9001:2008</p> </div> <div style="width: 50%;"> <p><i>Register-N° and Name of the notified body</i></p> <p>Bureau Veritas, Id. number 0062</p> </div> </div>	

Manufacturer's Declaration as per EC-Directives Page 2 of 2

Requirement EC 2006/42/Annex I	for Pneumatic actuators Series 92 und 93:
1.1.1, g) Actuator destination	See original installation and service instruction " OM0002E "
1.1.2.,c) foreseeable misuse	See original installation and service instruction " OM0002E "
1.1.2.,d) protecting measures for personnel	Same as the pipe section into which the valve is installed.
1.1.2.,e) accessories for maintenance	No special tools are necessary.
1.1.3 material in contact with the fluid	Actuator material in contact with the compressed pilot fluid is specified in the order acknowledgement and/or on the valve's marking. The relevant risk analysis is the responsibility of the user.
1.1.5 handling	See installation and service instruction " OM0002E "
1.2 and 6.2.11 control system	Is the responsibility of the user in combination with the instruction of the valve.
1.3.2 withstand to stresses	For parts under pressure: See declaration of conformity to the PED 97/23/EC For functional parts: Ensured at contractual use of the actuator.
1.3.4 sharp edges or angles	Requirements fulfilled.
1.3.7/8 risks related to moving parts	Requirements are fulfilled at contractual use of the actuator. No maintenance or service is allowed when the actuator is pressurized and/or it is connected to the control system. If an actuator Series 92 is upgraded with springs to become Series 93 (modified by the customer): For necessary protective measures ask BRAY for support.
1.5.1 – 1.5.3 energy supply	In the responsibility of the user in combination with the instruction of the valve.
1.5.7 -explosion	☞-protection may be necessary. This shall be confirmed by BRAY in the order acknowledgement.
1.5.13 emission of dangerous substances	Not applicable at not dangerous compressed fluids.
1.6.1 maintenance	See installation and service instruction no. " OM0002E "
1.7.3 marking	Actuator: see original installation and service instruction no " OM0002E " Valve: see valve instruction
1.7.4 service instruction	See original installation and service instruction no. " OM0002E " and valve instruction at standard actuator destination. At any special application additional notes and warnings may be necessary but are in the responsibility of the user.
Requirements from Annex III	The actuator is not a complete machine but a component only. No CE marking for conformity with the directive 2006/42/EG.
Requirements from Annexes IV, VIII & XI	Not applicable.

Requirements as per EN 12100	
1. Scope	Basis for the analysis is the Product Standard EN 15714-3: <Pneumatic Actuators>. <i>Note:</i> <i>For the requirements as per clauses 4 to 6 of EN 12100 it is assumed that the user has made a risk analysis for the valve/actuator unit installed into the pipe section under the service conditions– such analysis is not possible for BRAY.</i>
3.20, 6.1 inherent design	The actuator has been designed at the principles of <inherent safe design>.
Analyse as per clause 4, 5 and 6	The knowledge of documented malfunctions and misuse at the manufacturer BRAY as per ISO 9001 are the basis of this instruction.
5.3 Limits of the machine	The limits of the <component actuator> are defined as per clause A2 <Actuator destination> - and the limits of the valve/actuator interface as well.
5.4 Decommissioning, waste management	Not in the responsibility of the manufacturer BRAY
6.2.2 Geometric factors	The actuator shell (body, covers) enclose all moving parts of the actuator: no risk at use as defined in clause A2 of this instruction OM0002E. The position indicator (see photo in clause D2) is without risk as well. Therefore this section of the MD is not applicable.
6.3 Technical protective devices	not applicable.
6.4.5 Instruction	Valves with actuator operate automatically after connection to the plant control system. Necessary information for service and maintenance are included in section C of this instruction OM0002E.

Instruction Pneumatic Actuator with technical annex

for the actuator as a <Component>Pressure Directive 97/23/EG

INDEX	Page
Manufacturer's Declaration as per EC-Directives	1
A) General	
A1 Pictograms	4
A2 Actuator Destination	4
A3 Marking of the pneumatic actuator	5
A4 Transport und storage	5
B) Installation and functional check	
B1 Important safety warnings at installation	6
B2 Pre to install conditionan actuator at a valve	6
B3 <i>If necessary in site:</i> Steps at valve-actuator assembling	7
B4 Precondition to connect an electric unit	7
B5 Steps at actuator connection the control system	7
B6 Steps at positioner connection the control system (if any)	8
B7 Steps at actuator connection with bracket	8
B8 Testing steps at the end of installation	8
B9 Additional information Disassembling of the actuator from the valve	9
C) Service and maintenance	
C1 Important safety warnings at service and maintenance	10
C2 Commissioning	10
C3 Maintenance	10
C4 Troubleshooting	11
C5 Upgrading Series 92 to Series 93 (spring return)	12
D) Annex Technical & Project Data	
D1 Technical specification of Series 92 & 93	13
D2 Actuator technical data	13-16
D3 Drawing / Part List of Series 92 & 93	17

More information

This manual, BRAY-catalogue-pages and other information – even in other language – may be asked from sales@bray.de or from

BRAY Armaturen & Antriebe Europa
 Europark – Fichtenhain A , 13b · D-47807 Krefeld
Email: sales@bray.de
Tel: +49 2151 5336 0
Fax: +49 2151 5336 242



A General

This instruction may support the user to store, install, start-up, use and maintain Bray-pneumatic actuators Series 92, 93. It implies that all requirements of the pipe system and the pipe system control – as far as the actuator is concerned – are observed as well.

For the valve to which the actuator is assembled the user shall observe the corresponding manual.

A1 Pictograms

Warnings and notes of this manual are marked with pictograms:

	<p>Danger / Warning Points out a dangerous situation which may cause personal injuries or death..</p>
	<p>Advice Has to be respected</p>
	<p>Information Information useful to follow</p>

If these notes and warnings are not respected by the user, dangerous situations may occur and may invalidate the warranty of the manufacturer.

A2 Actuator Destination

A **BRAY-pneumatic actuator series 92** is destined

- after connection of a pilot (i.e. solenoid) valve at the interface as per VDI/VDE 3845,
- and after connection of this pilot valve to the plant control system,
- by the pilot fluid not higher as the value marked in the actuator nameplate,
- in a normal environment, minimal -40°C, maximal +95°C,
- at condition of permanent pilot pressure supply with max. 110% of the supply pressure marked in the actuator nameplate,

to operate valves with 90°-obturation (i.e. butterfly or ball valves) following the plant control signals. An actuator for a higher operation than 90° angle may be supplied on request.

Compressed air shall be dried, cleaned by a **40 µm filter** (ISO 8573-1, class 5) and should be slightly oiled at cycles >2/min. Other pilot fluids may be used on request.

A **BRAY-pneumatic actuator series 93** has additionally

- a „fail safe“-function to close / to open the valve at fail (or disconnection) of pilot pressure supply.

Instead of compressed air any neutral gas can be used – for water or oil ask BRAY for approval

All actuators series 92 can – even on site – be upgraded to series 93 by additional assembling of a set of springs – the BRAY-Documents B-1032 8/03 gives the necessary information, see Annex D.

An actuator correctly assembled to the valve indicates the valve position by a pointer in the top of the actuator housing. An (optional) set of <limit switches> signals the valve position to the plant control system. An (optional) unit <positoner> permits to switch the valve by a control signal into any rugged position between <fully open> and <fully closed>.

All requirements of clauses B1 & C1 <Important information for the user> shall be observed at installation and service as well.

Note 1:

A double-acting actuator series 92 remains in the actual position at pressure supply failure.

Under pilot pressure supply, but at interruption of the electric supply of the solenoid valve, it depends on the solenoid valve characteristic, if the actuator opens or closes.

If the customer has given no other order the solenoid valve (supplied by BRAY) shall close the valve at interruption or fail of the electric signal.

Note 2:

An actuator type „**fail safe to close**“ closes at the interruption of the pilot pressure supply. The function of the solenoid valve shall support this characteristic: At failure of the electric signal shall result the closing function as well.

An actuator type „**fail safe to open**“ opens at the interruption of the pilot pressure supply. The function of the solenoid valve shall support this characteristic: At failure of the electric signal shall result the opening function as well.

The solenoid valve shall be specified and installed to realize these functions accordingly.

Note 3:

At standard supply the mechanical position indication on TOP of the actuator is adjusted ex works for actuator mounting **parallel to the piping**.

A mounting **crosswise to the pipe** shall be specified expressly in the customers order.

A back fitting valve/actuator on site is possibly – ask for BRAY support – addresses see cover page (behind index).

An actuator correctly installed at a valve indicates the valve position by a pointer in the top of the actuator housing. An (optional) set of limit switches signals the valve position to the plant control system.

A3 Marking of the pneumatic actuator

Each actuator supplied is marked as follows:



Actuator marking (example)

The marking shall not be damaged or covered (do not paint over!) to permit the actuator identification if necessary.

A4 Transport and storage

The actuator – and valve/actuator units as well – shall be shipped and stored with care.

- Valve/actuator units shall not operate before installation.
- Handle actuator (or valve and actuator units) with care in its original packaging and protect it from harsh environmental conditions, such as dirt, debris and humidity.



If a hoist shall be used to handle a valve/actuator unit, follow the valve instruction.
A lifting device may be fixed at an actuator which is much heavier than the valve.



- If the actuator – and valve/actuator units as well – shall be stored before installation, store it at room temperature and protect it from harsh environmental conditions, such as dirt, debris and humidity.
- An actuator with electrical units shall be stored in a closed room at constant temperature to prevent condensation in the electric unit.

Unpack an actuator or valve/actuator units not earlier than just before installation.

B Installation and functional check



	<p><i>This instruction includes safety recommendations for foreseeable risks at installation into a (pipe and control) system.</i></p> <p>The user is responsible to complete this instruction with warning notes for system-specific aspects. All requirements of the system shall be observed.</p>
---	--

B1 Important safety warnings at installation

	<ul style="list-style-type: none"> • Installation shall be performed by qualified personal. Qualified are those persons who, due to experience, can judge the risks and execute the work correctly and who are able to detect and eliminate possible risks. • For actuator and actuator accessories the same safety warnings apply as for the relevant pilot pressure supply and the control system. The connection to these systems shall be made by the relevant experts. • At the end of the installation the function of the actuator shall be in accordance with the actuator and the valve destinations, see section A2. Specifically the supply pressure shall remain in the limits marked at the actuator housing. • An actuator supplied separately shall be assembled to the valve as supplied by BRAY – any modification – except retrofitting of a spring set (Series 92 → Series 93) – without approval of BRAY is forbidden and determines the manufacturer’s liability. • The actuator marking shall fit to the control system characteristics. • Any manual emergency operation shall be done at zero-pilot pressure only. For Series 93 such emergency operation shall be done by a self locking worm gear (optional supply) only. It is not permitted to use extension levers to increase the manual torque. • Emergency operation at a Series 93 actuator type shall be done by a special worm gear only, not at the upper end of the actuator shaft. Even for large sized actuators Series 93 such a device is • Protective devices at electric units shall remain in the supply condition. At the connection of the actuator unit to the plant control system interrupt all pressure and electric supply. If an electric unit shall be adjusted under electric current, use appropriate special tools.
 Danger	<ul style="list-style-type: none"> • At first time installation of a set of springs in site (to upgrade an actuator Series 92 → 93) ask BRAY for support. • Before opening of a cover of an actuator be sure that the pilot pressure in the actuator housing is zero.

B2 Precondition to install an actuator at a valve

- The valve – or an adapter between – shall have the same interface as per ISO 5211 as the actuator and the valve actuating shaft end or coupling shall fit to the actuator – see dimensional Table in the BRAY-document B-1032 8/03.
- Note:**
Double bolting circle in the actuator housing is usual.
- The correlation actuator↔valve shall be based on the valve manufacturer’s information, for actuator data see EN 15714-3 and the BRAY-document B-1032 8/03.
 - At standard supply of BRAY the actuator shall be installed **parallel to the pipe**.
For installation **crosswise** it shall be **reconstructed by the BRAY-Service on request** – see addresses at the index of this manual.

 Danger	<p><i>The (black) indicator in TOP of the actuator housing is adjusted accordingly.</i></p> <p>A wrong adjustment of this indicator at the actuator can be a dangerous misinformation and may cause injury of personnel in the plant and/or damage in the pipe section.</p>
	<p><i>Adjust the stroke of the actuator properly at the screws (Pos. 12, 13):</i></p> <p>This adjustment shall be made separately at the bolts in the actuator covers for both end positions „OPEN“ and „CLOSED“– observe the valve manual instruction.</p> <p>Do not unscrew a bolt completely from the actuator cover</p>

B3 *If necessary in site:* **Steps at valve-actuator assembling**

- As a standard the actuator output of both Series 92/93 are supplied with 2-flat (=“double D”) interface (only the large sizes 160B, 210 and 255 have a fitting key DIN 6885) for the actuator assembling to a valve **parallel to the valve**.

If necessary to reconstruct the actuator for crosswise installation: See above Clause B2.

Interface dimensions ISO 5211 see Section D2 in Annex.

- Fix the actuator with slightly oiled bolting 5.6/8.8 or A2/A4 (*slightly oiled*) and set tight with the following torque:

thread	M6	M8	M10	M12	M16	M20	M24
min. torque [Nm]	5	10	21	36	85	175	300

Table 1: Torque to fix the actuator at valve interface

- It is proposed to adjust the valve end positions „OPEN“ and „CLOSED“ after connection of the pilot pressure supply and the plant control system.

NOTE: It is easier to adjust an end stop screw in a position not fully charged by pilot pressure

B4 **Precondition to connect an electric unit**



When connecting an electric unit to the plant control system observe the information and warnings in the relevant documentation of this unit

- First ensure that the plant characteristics pilot fluid & pressure, voltage and frequency fit to the actuator & accessory. See actuator & accessory markings.

- Consumption & shifting time:

Series 92 can be taken from Table 2.

Note that the shortest time in this table is for an **actuator Series 92 without valve unit**: The friction in the valve and the effect of the spring set at Series 93 enlarge this theoretical value notably.

Size of actuator	48	63	83	92	118	127	160	210	255
Volume / stroke [dm ³] (for stroke 90°)	0,10	0,16	0,41	0,6	1,2	1,6	3,1	5,9	12,3
shortest shifting time [s] (approx.)	0,25			0,5			1	2	3

Table 2: Important actuator data Series 92

An actuator Series 93 has longer shifting time, 180°– an actuator has double pilot fluid consumption per stroke.



If the shifting time shall be longer then install a throttle (preferably) in the actuator exhaust at the solenoid valve and adjust it accordingly.

B5 **Steps at actuator connection the control system**

- The actuator has a standardized pilot connection as per (German) standard VDI/VDE 3845 (NAMUR), G ¼.

Affix solenoid valves with such interface preferably.

The pilot supply at the **left bore** (at front view) effects a **stroke anticlockwise** – at standard valve/actuator units **OPENING of the valve**.

The pilot supply at the **right bore** (at front view) effects a **stroke clockwise** – at standard valve/actuator units **CLOSING of the valve**.

Electric onnection of the solenoid valve to the control system: Follow the solenoid valve instruction.

- Afterwards adjust both position stops in the actuator covers as specified in the valve manufacturer’s instruction – see Clause B2 above.

See Clause D3, item 12 & 13, and detail scetch at the left.

	<p>Do not unscrew these stops item 12 completely!</p> <p>Each bolt item 12 can be adjusted effortlessly if not blocked by the pilot pressure in the „OPEN“ and „CLOSED“ positions:</p> <p>Reverse the valve position shortly – adjust the stop bolt Pos.12 and reverse again: When the valve position is OK: lock this position by the nut Pos.13.</p> <p><i>Note: Both stops can be adjusted +/-5°.</i></p>
---	--

- The (black) position indicator in TOP of the actuator housing shall indicate the valve obturator (= butterfly valve disc or ball boring) position correctly:
 - ▶ indicator **crosswise** to the pipe axis: **valve is CLOSED,**
 - ▶ indicator **parallel** to the pipe axis: **valve is OPEN,**

If not: Then:

 - ▶ the actuator is not correctly assembled to the valve: *Reassemble at 90° shifted,*
 - ▶ or the valve shaft is not correctly designed/assembled: *Consult valve manufacturer.*

	<p>Important</p> <p>A wrong adjustment of this indicator at the actuator can be a dangerous misinformation and may cause injury of personnel in the plant and/or damage in the pipe section. See also warning in Clause B2.</p>
---	---

B6 Steps at positioner connection the control system (if any)



Such an accessory can be (or is) installed in TOP of the actuator housing – replacing the (black) position indicator: This unit permits to switch the valve by a control signal into any rugged (stable) position between <fully open> and <fully closed>.

To connect it to the control system: Follow the positioner instruction.

NOTE:

If a positioner is disassembled from the actuator a groove in the upper shaft end of the actuator shall indicate the same cross-wise position as the black indicator described above.

This is ensured only if the end of the valve’s actuating shaft is of “double D” design.

	<p>Important</p> <p><i>Because the (black) position indicator has to be disassembled:</i> Ensure that the positioner has an individual position indicating device and adjust it accordingly as described in clause B5 (see above).</p>
	<p><i>If the actuator assembling position shall be 90° shifted:</i> Ensure the position indicator of the positioner is adjusted correctly. Information to adjusting see clause B5 <Steps at actuator connection....>.</p>

B7 Steps at actuator connection with bracket

Clauses B2 –B6 apply analogously at valve/actuator assembling with brackets between.

In that case it is the responsibility of the valve manufacturer or the user:

- ▶ to complete the risk analysis as per EN12100 for the exposed parts and to reduce or eliminate the risk for the user
- ▶ to ensure the correct position indication of the valve obturator position.

B8 Testing steps at the end of installation

At the end of installation, it is recommended categorically to check the following in coordination with the plant or installation supervisor:

- Is the pilot pressure sufficient in situ?
 At the solenoid valve the pilot pressure shall be the same as the base of valve/actuator allocation
- Is he solenoid valve (or positioner) connected correctly to the control system?
 At correct pilot pressure supply, **but at fail of the control signal** (*Check: Take-off the plug*) the actuator shall switch the valve as follows:

Actuator Series	The valve shall
Series 92	<i>if not otherwise defined in the customers:</i> switch in the „CLOSED“ position.
Series 93: spring to close	switch in the safety position „CLOSED“
Series 93: spring to open	switch in the safety position „OPEN“

If not correct, adjust the control signal of the solenoid valve accordingly.

- Check function & indication:
At pilot pressure supply at the solenoid valve and at the relevant control signal the actuator shall switch the valve into the end positions „**OPEN**“ und „**CLOSED**“.
The position indicator of the actuator (or positioner, if any) shall indicate the valve position correctly.

 Important	<p><i>In the CLOSED position of the valve:</i> The (black) position indicator of the actuator shall indicate the closed position crosswise to the pipe. A wrong adjustment of this indicator at the actuator can be a dangerous misinformation and may cause injury of personnel in the plant and/or damage in the pipe section. See also warning in Clause B2.</p> <p>At a safety-relevant valve in the plant, this should be confirmed by the responsible safety supervisor.</p> <p>NOTE: If a positioner is disassembled from the actuator a groove in the upper shaft end of the actuator shall indicate the same crosswise position as the black indicator described above.</p> <p>This is ensured only if the end of the valve's actuating shaft is of "double D" design.</p>
---	---

- Check the interface bolting
At the functional test, no relative movement shall occur between valve, actuator housing (and brackets, if any).
If necessary fasten the bolting – see Table 1 in Clause B3 <steps to install>.

At any fail, observe clause C4 <troubleshooting>.

B9 Additional information **Disassembling of the actuator from the valve**

Observe the same safety measures as for the plant control and pilot supply system.

- Disconnect all electric connections.
- Decompress and bleed the pipe section at the solenoid valve (or positioner).

	<p>Observe that an actuator Series 93 need sufficient time to decompress to switch into the safety position.</p>
---	--



- Note and mark the position of the actuator housing relative to the valve (or bracket), then loosen all actuator connections.
- Loosen the bolting at the interface ISO 5211 (valve/actuator or bracket/actuator).
- Check all interface surfaces at the actuator output to be without wear – or replace worn parts – see addresses in the end of the Index.
- When temporary storage is necessary, observe clause A4.

C) Service and maintenance

The user shall make a risk analysis as per Machinery Directive 2006/42/EC for the pipe system. BRAY supplies the following documents for it:

- This installation and service instruction of the valve.
- The manufacturer's declaration(s) to EC Directives.

C1 Important safety warnings at service and maintenance

	<ul style="list-style-type: none"> • Installation shall be performed by qualified personal. Qualified are those persons who, due to experience, can judge the risks and execute the work correctly and who are able to detect and eliminate possible risks. • At the end of the installation and at service the function of the actuator shall be in accordance with the actuator destination, see section A2 and the actuator marking. Specifically the supply pressure shall remain in the limits marked at the actuator housing. For any use other than this destination the agreement of <i>BRAY</i> is necessary. • To operate an actuator manually normal manual force is sufficient. It is not permitted to use extension levers at a handwheel to increase the torque. • An actuator shall be used as supplied by BRAY – any modification – except retrofitting of a spring set (Series 92 → Series 93) – without approval of BRAY is forbidden and determines the manufacturer's liability.
 <p>Danger!</p>	<ul style="list-style-type: none"> • When the interface bolting actuator/valve (or bracket) shall be loosened decompress and bleed first the pilot pressure supply. • An actuator Series 93 shall be disassembled in the <fail-safe>-position (=without pressure) only – at the interface bolting loosening the actuator may pivot some degrees (°) when the valve end position is based at an end stop in the valve (and not in the actuator).
 <p>Danger to jam one's fingers!</p>	<p><i>Valve not properly installed in a pipe section: :</i></p> <p>Danger of jamming one's hand or fingers between valve body and ball or disc: Do not operate an actuator disassembled from to the pipe system!</p> <p>Any actuating of a valve not installed is the full responsibility of the user.</p>

C2 Commissioning

After full testing only as per clause B8 the actuator shall be commissioned. The valve manufacturer's manual may give some additional advice.

The automatic service of the actuator shall follow the control signals. The actuator data are described in the Table in Annex D2.

	<p>Attention au service avec un temps de manoeuvre très court:</p> <p><u>Wear at the valve</u> and/or <u>water hammer in the pipe section</u> may occur. By .</p> <p>If the shifting time shall be longer then install a throttle (preferably) in the actuator exhaust at the solenoid valve and adjust it accordingly</p>
---	---

Only in case of ambient temperatures >50°C the actuator shall be protected from touch by fingers.

C3 Maintenance

Actuators Series 92/93 do not need specific maintenance.

It is sufficient to check the pilot fluid supply piping to remain tight: No leakage shall occur. When necessary observe clause C4 <troubleshooting>.

- la connexion entre le servomoteur et le robinet doit être serrée proprement. En cas de jeu, il faut serrer la boulonnerie selon Clause B6.
- check the pilot fluid supply piping to remain tight: No leakage shall occur. When necessary observe clause C4 <troubleshooting>

If the shifting time shall be longer then install a throttle (preferably) in the actuator exhaust at the solenoid valve and adjust it accordingly.

But observe maintenance instruction of actuator accessories – if any.

C4 Troubleshooting

!	<p>At any troubleshooting, respect the requirements of clause B2 & C2 <Important safety warnings..>.</p> <p>Order spare parts with all making information at the actuator (and accessory) housing .</p>
----------	--

Note: More troubleshooting may be included in the relevant instruction(s) of the electric units (if any).

Possible Defect	Remedy																
If an actuator type fail-safe shall be disassembled from the valve	 Danger Do not disassemble the actuator from a valve as long as the pilot pressure supply to the actuator is not interrupted.																
The actuator doesn't follow the plant control signal(s)	<p><i>Check the pilot pressure supply at the actuator:</i> The pressure should be as marked at the actuator nameplate.</p> <p><i>If the pilot pressure is sufficient, but the actuator doesn't move:</i> Check, if the valve functional parts have a too high friction: If yes, follow the relevant valve manual instructions.</p> <p><i>If there is no default in nor in the actuator, nor in the valve:</i> Check the plant control signals to be correct – if this is OK, replace the actuator.</p>																
The solenoid valve doesn't operate	<p><i>Check, if the coil is burned:</i> If yes, replace the coil. But check, if the electric coil data correspond with die plant control data.</p> <p><i>If the coil is OK:</i> Follow the solenoid valve instruction.</p>																
The stroke-operating time is too fast	<p>Install a combined throttle/check-valve in the pilot pressure supply/exhaust and adjust it properly. See Clause C2 as well.</p>																
The actuator operates, but the torque is not sufficient for the full stroke (specifically for the full CLOSED position)	<p>Check the end stop adjustment in the actuator:</p> <p><i>If – under pilot pressure at the CLOSE-function – the end stop is easy to turn:</i> In this case, the valve fails, not the actuator. Follow the actuator manual.</p> <p><i>If – under pilot pressure at the CLOSE-function – the end stop is locked:</i> Inverse the pilot plant signal to the OPEN position, the end stop is free to be adjusted properly.</p> <p>Inverse the pilot plant signal to the CLOSED position again and check the valve to be in the correct CLOSED position: If yes, secure this position of the end stop, if not, repeat the procedure.</p>																
Leakage of compressed air to outside or: The actuator consummates compressed air even in the end position	<p>Check the solenoid valve function and check, if it is fixed properly.</p> <p><i>If no leakage is detected:</i> Disassemble the actuator and replace or repair it. More information shall be asked from the actuator or accessory manufacturer for repair.</p>																
Leakage between the actuator housing and cover	<p><i>Tighten the housing/cover bolting:</i> Fasten crosswise bolts 5.6/8.8 or A2/A4, <i>slightly oiled with:</i></p> <table border="1" style="margin-left: auto; margin-right: auto; border-collapse: collapse;"> <tr> <td style="padding: 2px;">thread</td> <td style="padding: 2px;">M6</td> <td style="padding: 2px;">M8</td> <td style="padding: 2px;">M10</td> <td style="padding: 2px;">M12</td> <td style="padding: 2px;">M16</td> <td style="padding: 2px;">M20</td> <td style="padding: 2px;">M24</td> </tr> <tr> <td style="padding: 2px;">torque [Nm]</td> <td style="padding: 2px;">4</td> <td style="padding: 2px;">10</td> <td style="padding: 2px;">20</td> <td style="padding: 2px;">36</td> <td style="padding: 2px;">80</td> <td style="padding: 2px;">160</td> <td style="padding: 2px;">300</td> </tr> </table> <p><i>If leakage cannot be eliminated:</i> Replace cover sealing and/or ask BRAY-service for support.</p>	thread	M6	M8	M10	M12	M16	M20	M24	torque [Nm]	4	10	20	36	80	160	300
thread	M6	M8	M10	M12	M16	M20	M24										
torque [Nm]	4	10	20	36	80	160	300										
Other functional defect	<p><i>Check the connection of the bolting between valve, attachment elements (if any) and actuator:</i> If loosened, fixed all bolts properly. If the bolting is OK, disassemble the actuator and replace or repair it – ask BRAY-service for support.</p>																

C5 Upgrading Series 92 to Series 93 (= spring return) See drawing/Table in Annex D2,D3

	<p>Danger: Switch the actuator into the relevant end position and depressurize and bleed the actuator for upgrading and disconnect the solenoid valve.</p>
<p>Upgrading Series 92 to function: spring to close</p>	<ul style="list-style-type: none"> ▶ follow Table in clause D2 to choose the spring set according to pilot pressure. ▶ Order spring set from BRAY – use only the Bray „precompressed springs“! ▶ Disassemble both covers of an actuator Series 92 and distribute the necessary number of springs symmetrically as follows: <ul style="list-style-type: none"> ● first put in 50% of the set into the chamber right - observe Table and Fig, in clause D2 ● then put in 50% of the set into the chamber left - observe Table and Fig, in clause D2 ▶ then attach both covers 4 and the relevant bolting 17 by hand, ▶ and fasten both covers crossover in little steps to prevent to cant the cover – fasten it finally with torque in Table C4. ▶ Reconnect the pilot pressure and electric connection of the solenoid valve and check the correct function. Ensure the actuator capacity to be sufficient for both directions.
<p>Upgrading Series 92 to function: spring to open</p>	<ul style="list-style-type: none"> ▶ follow Table in clause D2 to choose the spring set according to pilot pressure. ▶ Order spring set from BRAY – use only the Bray „precompressed springs“! ▶ Bring the actuator in full CLOSED position, disassemble both covers of the actuator. ▶ Pull out each cylinder 2 and reassemble it in 180° rotated position – do not operate the actuator shaft meanwhile. ▶ Then distribute the necessary number of springs symmetrically as follows: <ul style="list-style-type: none"> ● first put in 50% of the set into the chamber right - observe Table and Fig in clause D2 ● then put in 50% of the set into the chamber left - observe Table and Fig in clause D2 ▶ then attach both covers 4 and the relevant bolting 17 by hand, ▶ and fasten both covers crossover in little steps to prevent to cant the cover – fasten it finally with torque in Table C4. ▶ Reconnect the pilot pressure and electric connection of the solenoid valve and check the correct function. Ensure the actuator capacity to be sufficient for both directions.

D) Annex Technical & Project Data

Note:

This clause is no integral part of the „**Instruction Pneumatic actuator OM00012E-1**“ but an extract from the BRAY-catalogue <Ball Valves & Actuators, Product Manual>. More details may be found in this document.

D1 Technical specification of Series 92 & 93

The actuator conforms to

- EN15714: <Actuators for Industrial Valves: Part 3: Pneumatic actuators>

D2 Actuator technical data



Double Acting/
Spring Return

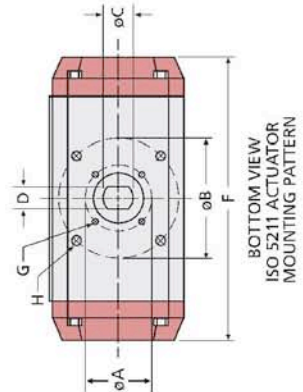
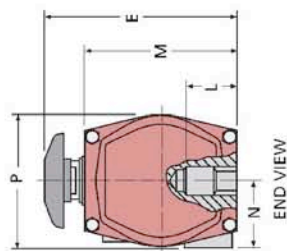
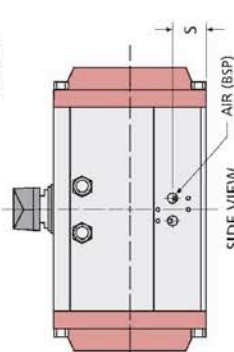
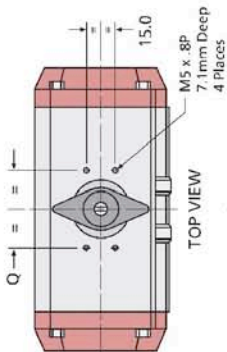

Special Note: Sizes 210 and 255 actuators have endcap travel stops not bi-directional travel stops. Please consult factory for production release date of bi-directional stops for these size 92/93 actuators.

SERIES 92/93 DIMENSIONS

SIZE	48	63	83	92	118	127	160*	210	255 [‡]
AIR BSP	G1/8	G1/4	G1/4	G1/4	G1/4	G1/4	G1/4	G1/4	G1/4
A ISO-F [†]	35 F03	50 F05	50 F05	70 F07	70 F07	70 F07	—	125 F12	165 F16
B ISO-F [†]	50 F05	70 F07	70 F07	125 F12	125 F12	125 F12	125 F12	165 F16	200 x 120 Rect.
C	14	14	19	19	30	30	30	50	64
D	10	10	13	13	22	22	22	12	16
E	99	115	138	147	185	205	238	291	339
F	102	142	188	218	302	313	395	452	678
G	M5 x 6	M6 x 8	M6 x 8	M6 x 8	M8 x 12	M8 x 12	—	M12 x 20	M16 x 2 x 28mm
H	M6 x 6	M8 x 10	M8 x 10	M8 x 10	M12 x 18	M12 x 18	M12 x 20	M16 x 28	M16 x 2 x 28mm
J	10	10	13	13	28	28	28	28	28
L	33	35	37	37	56	56	56	70	108
M	64	88	108	117	140	161	198	255	302
N	41	44	51	55	64	69	78	108	121
P	56	79	97	106	125	138	173	224	273
Q	40	40	40	40	40	40	65	65	65
S	32	23	23	24	35	35	35	37	38
T	28**	20	20	20	20	20	30	30	30
U	12	12	12	12	12	12	19	19	19

Note: Double Acting and Spring Return actuators have the same overall dimensions. The double acting unit of the size 48 actuator is optionally available with flat end caps with an F dimension of 4.00.
 * Dimensions for Size 160A in table. Size 160B (keyed stem version) has a C dimension of 35 and D dimension of 10.
 † Dimensions for Size 255A in table. Size 255B actuator has a C dimension of 76.2 and D dimension of 19.
 ‡ Size 255C has a C dimension of 60 and a D dimension of 18. Size 255D has a C dimension of 75 and a D dimension of 20.
 ** Size 48 has a T dimension of 20 with use of NAMUR top plate.

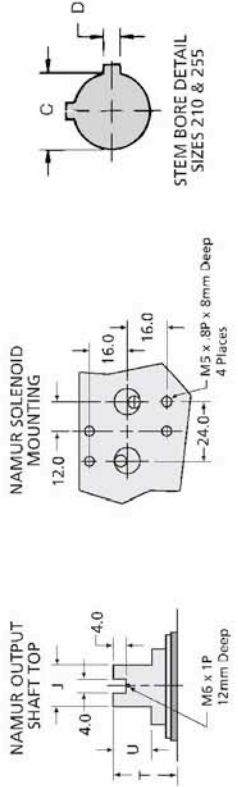

Actuator Speeds (Seconds)

SIZE	48	63	83	92	118	127	160	210	255
Open Stroke/Close Stroke	0.25	0.25	0.25	0.25	0.5	0.5	1.0	2.0	2.75

Times are in seconds, at 5.5 bar with 2 meters tubing, internal diameter approximately 6mm.

Actuator Weights (kgs)

SIZE	48	63	83	92	118	127	160	210	255
Double Acting	.08	1.5	2.8	3.8	7.4	9.5	17.3	29.5	65.3
Spring Return	1.1	1.9	3.6	4.9	9.8	12.4	23.9	43.2	87.4

Weights are in kgs. Spring Return unit weights are with full set of springs per piston.

Actuator Volumes (cm³)

SIZE	48	63	83	92	118	127	160	210	255
Counter-clockwise	93.4	157.3	406.4	570.3	1209.4	1584.6	3072.6	5889.3	12290.3
Clockwise	78.7	219.6	534.2	752.2	1565.0	2143.4	4254.1	7374.2	14748.4

Counter-clockwise: Air volume in cubic centimeters required to push pistons apart, full travel.
 Clockwise: Air volume in cubic centimeters required to push pistons together, full travel.

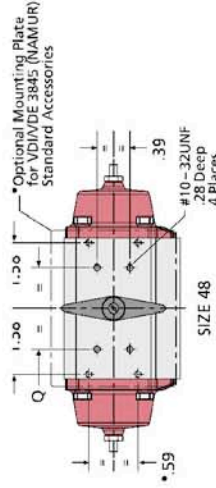

DOUBLE ACTING TORQUE CURVE

Series 92 – (Air to Air)

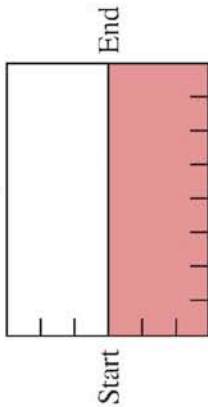

The Series 92 Actuator has a constant output torque throughout travel from start to end, clockwise or counterclockwise rotation.

SERIES 92 ACTUATOR TORQUE DATA (Nm)

Double Acting Pneumatic Operated Torque Output

Actuator Size	Air Supply Pressure (bar)					
	3	4	5.5	7	8	
48	8.5	12.8	16.9	21.2	25.4	
63	16.4	25.0	33.6	42.1	50.7	
83	39.7	60.6	81.5	102.4	123.3	
92	55.7	85.1	114.5	143.7	173.1	
118	119.5	182.5	245.3	308.2	371.2	
127	159.3	243.1	327.0	410.8	494.6	
160	316.0	482.4	648.8	815.1	981.5	
210	653.4	997.2	1341.1	1685.1	2028.9	
255	1605.6	2450.8	3295.9	4140.9	4986.0	

SINGLE ACTING TORQUE CURVES

Series 93 – (Spring Return)

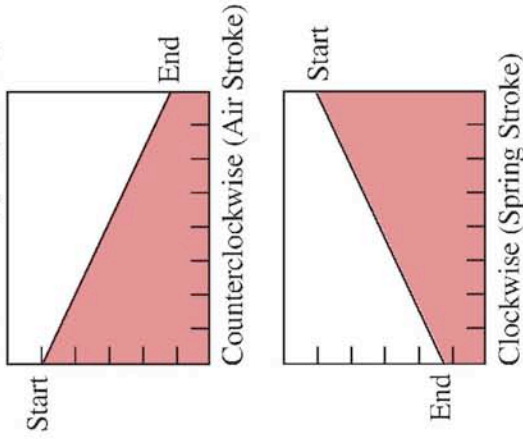

SERIES 93 ACTUATOR TORQUE DATA (Nm)

Air Operated, With Spring Return, Torque Output

Actuator Size	No. Springs per Piston	Air Supply Pressure (bar)																	
		3			4			5.5			7			8			Spring Stroke		
		Start	End	Start	End	Start	End	Start	End	Start	End	Start	End	Start	End	Start	End		
48	1	5.8	3.6	10.1	7.9	14.2	12.1	18.5	16.4	22.7	20.6	4.9	2.7						
	2/1	4.4	1.1	8.7	5.4	12.9	9.6	17.2	13.9	21.4	18.1	7.3	4.1						
	2			7.2	3.1	11.4	7.2	15.7	11.5	19.9	15.7	9.7	5.5						
	3/2			5.9	0.6	10.1	4.7	14.3	9.0	18.5	13.2	12.2	6.9						
	3					8.77	2.4	13.0	6.7	17.2	10.8	14.6	8.2						
	2	10.3	7.3	18.9	15.9	27.5	24.5	36.0	33.1	44.6	41.7	9.0	6.1						
63	3	7.2	3.1	15.8	11.6	24.4	20.2	33.0	28.8	41.6	37.4	13.3	9.2						
	4			12.8	7.3	21.4	15.9	29.9	24.5	38.5	33.1	17.6	12.2						
	5			9.7	3.1	18.3	11.6	26.9	20.2	35.5	28.8	21.9	15.3						
	6					15.3	7.3	23.8	15.9	32.4	24.5	26.2	18.3						
	2	23.7	18.9	44.6	39.8	65.5	60.7	86.4	81.6	107.3	102.5	20.8	15.9						
	3	17.6	8.6	38.5	29.5	59.4	50.4	80.3	71.3	101.2	92.2	31.1	22.0						
83	4			31.7	19.9	52.7	40.8	73.6	61.7	94.5	82.6	40.7	28.8						
	5			24.9	11.0	45.8	31.9	66.7	52.8	87.6	73.7	49.6	35.7						
	6					41.7	20.9	62.6	41.8	83.5	62.7	60.6	39.8						
	2	35.0	26.2	64.4	55.6	93.8	85.0	123.0	114.2	152.4	143.6	29.5	20.7						
	3	24.6	11.4	54.0	40.8	83.4	70.2	112.6	99.4	142.0	128.8	44.3	31.1						
	4			43.6	26.1	73.0	55.5	102.3	84.7	131.6	114.1	59.0	41.5						
92	5			33.2	10.6	62.6	40.0	91.9	69.3	121.2	98.6	74.5	51.9						
	6					52.2	25.9	81.5	55.1	110.8	84.5	88.6	62.3						

118	2	78.2	53.0	141.1	115.9	203.9	178.7	266.9	241.7	329.8	304.6	66.5	41.4
	3	57.5	19.7	120.4	82.6	183.3	145.4	246.2	208.3	309.1	271.3	99.9	62.0
	4			99.8	49.4	162.6	112.2	225.5	175.1	288.5	238.1	133.1	82.7
	5			79.1	16.0	141.9	78.9	204.8	141.8	267.8	204.7	166.4	103.4
	6					121.2	45.6	184.2	108.6	247.1	171.5	199.6	124.1
	2	99.4	52.5	183.3	136.4	267.1	220.2	350.9	304.0	434.8	387.9	106.8	59.9
127	3	0.0	0.0	153.3	82.8	237.2	166.7	321.0	250.5	404.8	334.3	160.3	89.8
	4	0.0	0.0	123.6	29.5	207.4	113.3	291.3	197.2	375.1	281.0	213.7	119.5
	5	0.0	0.0	0.0	0.0	177.2	59.8	261.0	143.6	344.8	227.4	267.2	149.6
	6	0.0	0.0	0.0	0.0	147.1	6.4	230.9	90.3	314.8	174.1	320.5	179.9
	2	205.5	126.3	371.9	292.7	538.3	459.1	704.6	625.4	871.0	791.8	189.7	110.5
	3	158.1	39.4	324.5	205.9	490.8	372.2	657.1	538.5	823.5	704.9	276.6	158.0
160	4			277.0	126.9	443.4	293.2	609.7	459.5	776.1	625.9	355.6	205.4
	5			229.4	39.9	395.7	206.2	562.0	372.5	728.4	538.9	442.6	253.1
	6					356.4	135.1	522.7	301.4	689.1	467.9	513.6	292.4
	2	433.1	283.4	776.9	627.2	1120.8	971.1	1464.7	1315.0	1808.5	1658.8	370.0	220.3
	3	323.0	98.1	668.8	441.9	1010.8	785.8	1354.7	1129.7	1698.5	1473.5	555.3	330.4
	4			557.0	257.0	900.9	601.0	1244.9	944.9	1588.7	1288.7	740.2	440.2
210	5			446.2	72.1	790.1	416.0	1134.0	759.9	1477.8	1103.7	925.1	551.0
	6					680.4	229.5	1024.3	573.4	1368.1	917.2	1111.7	660.7
	2	1071.9	762.3	1917.0	1607.4	2762.4	2329.6	3607.2	3297.6	4452.3	4142.7	843.3	533.7
	3	805.0	340.6	1650.1	1185.8	2495.3	2030.9	3340.3	2875.9	4185.4	3721.0	1265.0	800.6
	4			1383.3	764.0	2228.4	1609.1	3073.4	2454.1	3918.5	3299.3	1886.8	1067.5
	5			1116.3	342.3	1961.4	1187.5	2806.4	2032.5	3651.6	2877.6	2108.4	1334.5
6					1694.5	765.8	2539.6	1610.8	3384.7	2456.0	2530.1	1601.3	



D3 Drawing / Part List of Series 92 & 93

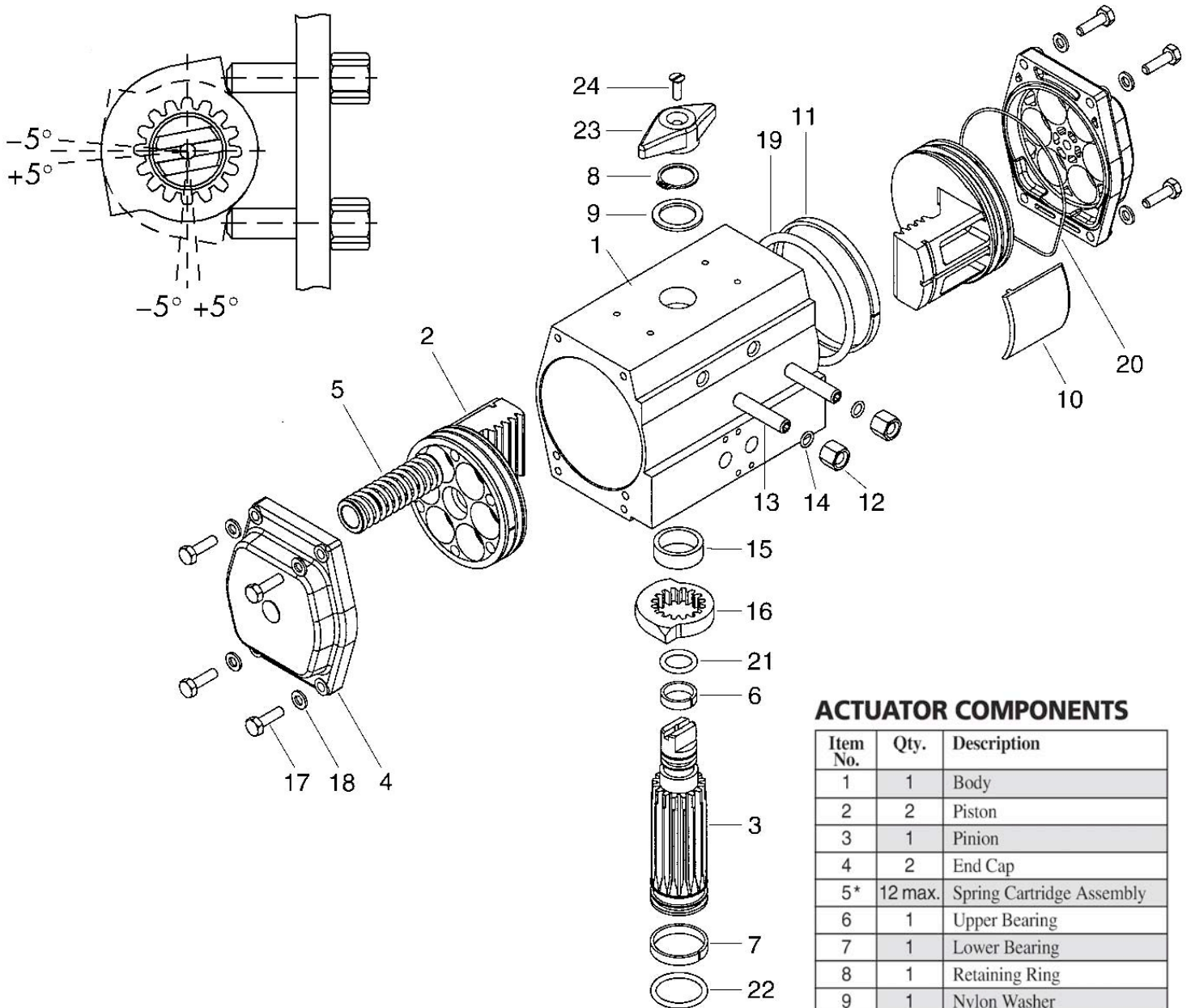

ACTUATOR COMPONENTS

Item No.	Qty.	Description
1	1	Body
2	2	Piston
3	1	Pinion
4	2	End Cap
5*	12 max.	Spring Cartridge Assembly
6	1	Upper Bearing
7	1	Lower Bearing
8	1	Retaining Ring
9	1	Nylon Washer
10	2	Acetal-Bearing Pad
11	2	Acetal-Guide Ring
12	2	Stop Nut
13	2	Travel Adjusting Screw Stop
14	2	O-Ring-Travel Stop
15	1	Acetal Spacer
16	1	Travel Stop
17	8	Hex Head Cap Screw
18	8	Washer
19	2	O-Ring-Piston
20	2	O-Ring-End Cap
21	1	O-Ring-Shaft-Top
22	1	O-Ring-Shaft-Bottom
23	1	Indicator Pointer
24	1	Indicator Pointer Screw